



INSTALLATION AND MAINTENANCE MANUAL
FOR SWING DOOR



Over – Over Evo – Over Heavy

1. INTRODUCTION

Before you begin to install or start an automatic pedestrian doors, an inspection must be carried out on site by qualified personnel, for making measurements of the compartment wall, door and drive.

This inspection is to assess the risk and to select and implement the most appropriate solutions according to the type of pedestrian traffic (intense, narrow, one-way, bi-directional, etc.), The type of users (elderly, disabled, children, etc.), in the presence of potential hazards or local circumstances.

To assist installers in applying the requirements of European Standard EN 16005 concerning the safe use of automatic pedestrian doors, we recommend consulting the guides E.D.S.F. (European Door and Shutter Federation) available on www.edsf.com.

1.1 GENERAL SAFETY INSTRUCTION

This installation manual is intended for professionally competent personnel only. Before installing the product, carefully read the instructions.

Bad installation could be hazardous. The packaging materials (plastic, polystyrene, etc.) should not be discarded in the environment or left within reach of children, as these are a potential source of hazard.

Before installing the product, make sure it is in perfect condition. Do not install the product in an explosive environment and atmosphere: gas or inflammable fumes are a serious hazard risk.

Before installing the automations, make all structural changes relating to safety clearances and protection or segregation of all areas where there is risk of being crushed, cut or dragged, and danger areas in general.

Make sure the existing structure is up to standard in terms of strength and stability. Aprimatic srl is not responsible for failure to use Good Working Methods in building the frames to be motorised or for any deformation occurring during use.

The safety devices (safety sensor, photocells, etc.) must be installed taking into account: applicable laws and directives, Good Working Methods, installation premises, system operating logic and the forces developed by the motorised door.

Apply hazard area notices required by applicable regulations.

Each installation must clearly show the identification details of the automatic pedestrian door.

1.2 EC MARKING AND EUROPEAN DIRECTIVES



Aprimatic automations for swing pedestrian door, are designed and manufactured in compliance with the safety requirements of the European standard EN 16005 and are CE-marked in accordance with the following European Directives:

Low Voltage Directive (2006/95/EC) and the Electromagnetic Compatibility Directive (2004/108/EC).

The automation APRIMATIC also include a Declaration of Incorporation according to the Machinery Directive (2006/42/EC).

Pursuant to Machinery Directive (2006/42/CE) the installer who motorises a door or gate has the same obligations as the manufacturer of machinery and as such must:







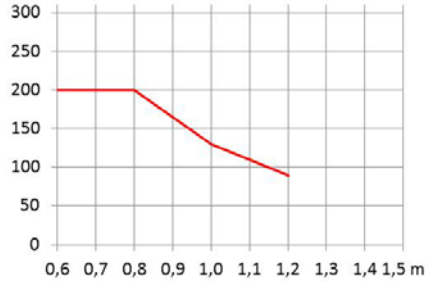

- prepare the technical file which must contain the documents indicated in Annex V of the Machinery Directive; (The technical file must be kept and placed at the disposal of competent national authorities for at least ten years from the date of manufacture of the pedestrian door);
- draft the EC declaration of conformity in accordance with Annex II-A of the Machinery Directive and deliver it to the customer;
- affix the CE marking on the power operated door in accordance with point 1.7.3 of Annex I of the Machinery

All data and information contained in this manual have been drawn up and checked with the greatest care. However APRIMATIC . cannot take any responsibility for eventual errors, omissions or inaccuracies due to technical or illustrative purposes.

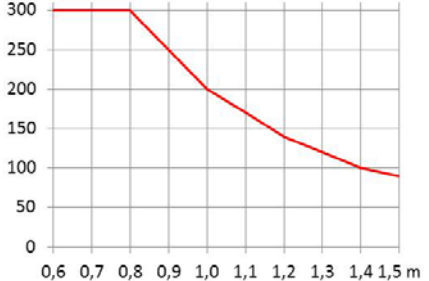
APRIMATIC reserves the right to make changes and improvements to their products. For this reason, the illustrations and the information appearing in this document are not definitive.

This edition of the manual cancels and replaces all previous versions. In case of modification will be issued a new edition.

2. TECHNICAL DATA

OVER	OVER EVO	OVER HEAVY
Automation type: LIGHT (for internal use, not exposed to wind pressure)	Automation type: SPRING (with closing spring)	Automation type: HEAVY
Dimensions: 82 x 117 x 443 mm (Height x Depth x Length)	Dimensions: 135 x 118 x 503 mm (Height x Depth x Length)	Dimensions: 104 x 118 x 463 mm (Height x Depth x Length)
200 kg x 0,8 m 	220 kg x 0,8 m 	300 kg x 0,8 m 
Opening and closing time: 2 – 6 s	Opening and closing time: 2 – 6 s	Opening and closing time: 2 – 6 s
Duty class: Continuous operation Intermittent operation: S3 = 100%	Duty class: Continuous operation Intermittent operation: S3 = 100%	Duty class: Continuous operation Intermittent operation: S3 = 100%
Power supply: 100–240 Vca 50/60 Hz Rated power: 40 W Stand-by: 8 W	Power supply: 100–240 Vca 50/60 Hz Rated power: 70 W Stand-by: 8 W	Power supply: 100–240 Vca 50/60 Hz Rated power: 70 W Stand-by: 8 W
Rated load: 20 Nm	Rated load: 23 Nm	Rated load: 40 Nm
Protection rating: IP 20	Protection rating: IP 20	Protection rating: IP 20
Operating temperature:  -15 °C  +50 °C	Operating temperature:  -15 °C  +50 °C	Operating temperature:  -15 °C  +50 °C
Parameter Settings: Buttons and Display	Parameter Settings: Buttons and Display	Parameter Settings: Buttons and Display
Connections to control and safety devices: Dedicated connecting terminals	Connections to control and safety devices: Dedicated connecting terminals	Connections to control and safety devices: Dedicated connecting terminals
Power output for accessories: 12 Vdc (1 A max)	Power output for accessories: 12 Vdc (1 A max)	Power output for accessories: 12 Vdc (1 A max)
Memory for settings and saving: Micro SD standard	Memory for settings and saving: Micro SD standard	Memory for settings and saving: Micro SD standard
PC connection: Micro USB standard	PC connection: Micro USB standard	PC connection: Micro USB standard
Function selector device with transponder key: FSD1	Function selector device with transponder key: FSD1	Function selector device with transponder key: FSD1
Battery power device for emergency opening: OVER	Battery power device for emergency opening: OVER HEAVY	Battery power device for emergency opening: OVER HEAVY
Signal of door position	-	Signal of door position

N.B. The technical data above refer to average conditions of use and cannot be certain in each case. Each automatic entrance variables such as: friction, balancing and environmental conditions that may substantially change both the duration and the quality of the operation of the automatic or some of its components, including the automation. The installer must to adopt adequate safety coefficients for each particular installation.

3. STANDARD INSTALLATION



Rif.	Code	Description
1	42605/001	OVER automation (Light) for swing doors
	42605/003	OVER EVO automation (Spring) for swing doors
	42605/002	OVER HEAVY automation (Heavy) for swing doors
2	42605/051	Sliding arm
3	SD3	Infrared safety sensor
4	OS1	Unidirectional microwave opening sensor
5	42605/060	Electronic function selector with transponder key
-	42605/070	Battery power device for OVER automation
	42605/071	Battery power device for OVER EVO and OVER HEAVY automation

Note: Components and codes are those most commonly used in systems for automatic swing doors. The full range of equipment and accessories is also available in the sales list.

The given operating and performance features can only be guaranteed with use of APRIMATIC accessories and safety devices.

4. ASSEMBLY PROCEDURE OF THE AUTOMATION

Check the stability, the weight of the leaf and that the movement is smooth and without friction (if necessary to reinforce the frame). Any closing door device must be removed or completely deactivated.

Check the correct operation in case of installation on doors that divide environments at different pressures.

4.1 INSTALLATION OF OVER AUTOMATION WITH SWSA SLIDING ARM

Use the sliding arm to pull with doors which open inside (view from the automation).

Remove the cover and fix the automation in a stable and leveled way to the wall using the measurements shown in the figure; refer to the axis of the door hinges.

Fix the sliding arm on the door as shown in the figure. Insert the sliding arm in the guide and fix to the automation.

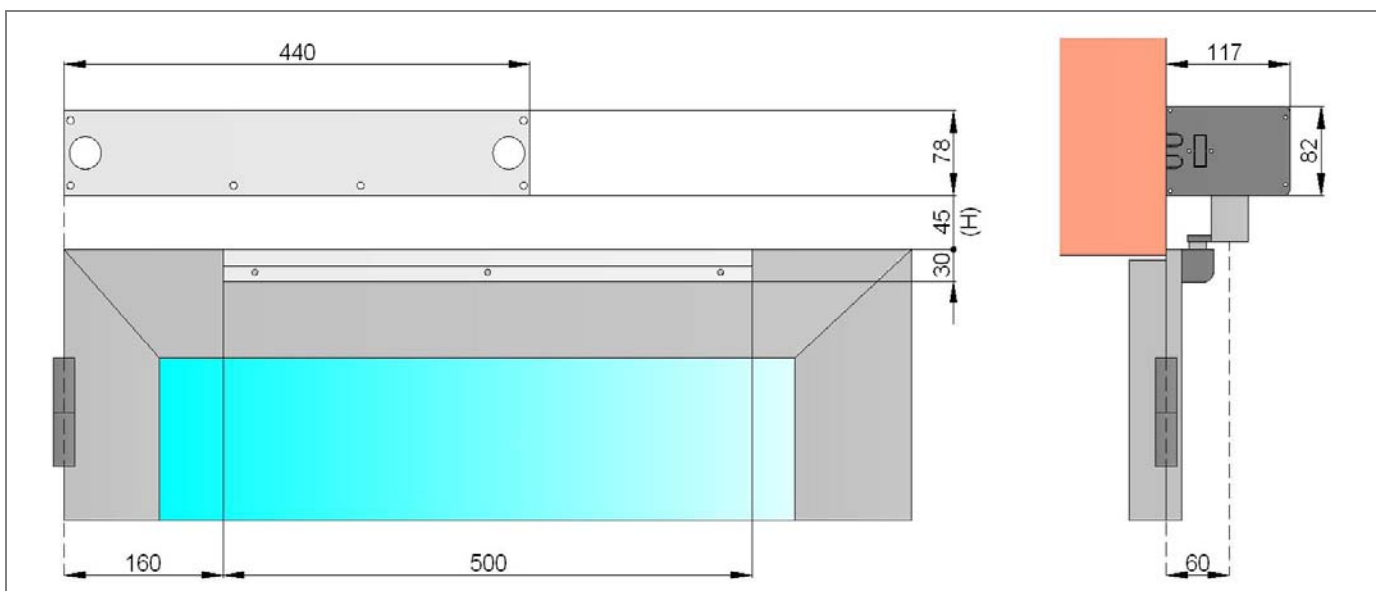

Note: if necessary, you can change the measure H, between the automation and the door, by replacing the spacer, using the codes listed in the table.

(H)	OVER automation
28	Sliding arm + Spacer 17mm
45	Sliding arm
62	Sliding arm + Spacer 51mm

Move the door manually, and verify the correct opening and closing smoothly.

Adjust the opening mechanical stop inside the sliding arm.

CLOSING OF THE AUTOMATION COVER

Insert the cover profile to the base profile and attach it to the heads. To prevent the cover from being opened without the use of a tool, you can remove the pins inserted into the cover, and secure the cover to the heads at the holes, using the screws 2,9 x9,5 not supplied by us.

4.2 INSTALLATION OF OVER AUTOMATION WITH ARTICULATED ARM

Use the articulated arm to push with doors which open outside (view from the automation).

Remove the cover and fix the automation in a stable and leveled way to the wall using the measurements shown in the figure; refer to the axis of the door hinges.

Fix the bracket of the articulated arm on the door, using the measurements shown in the figure.

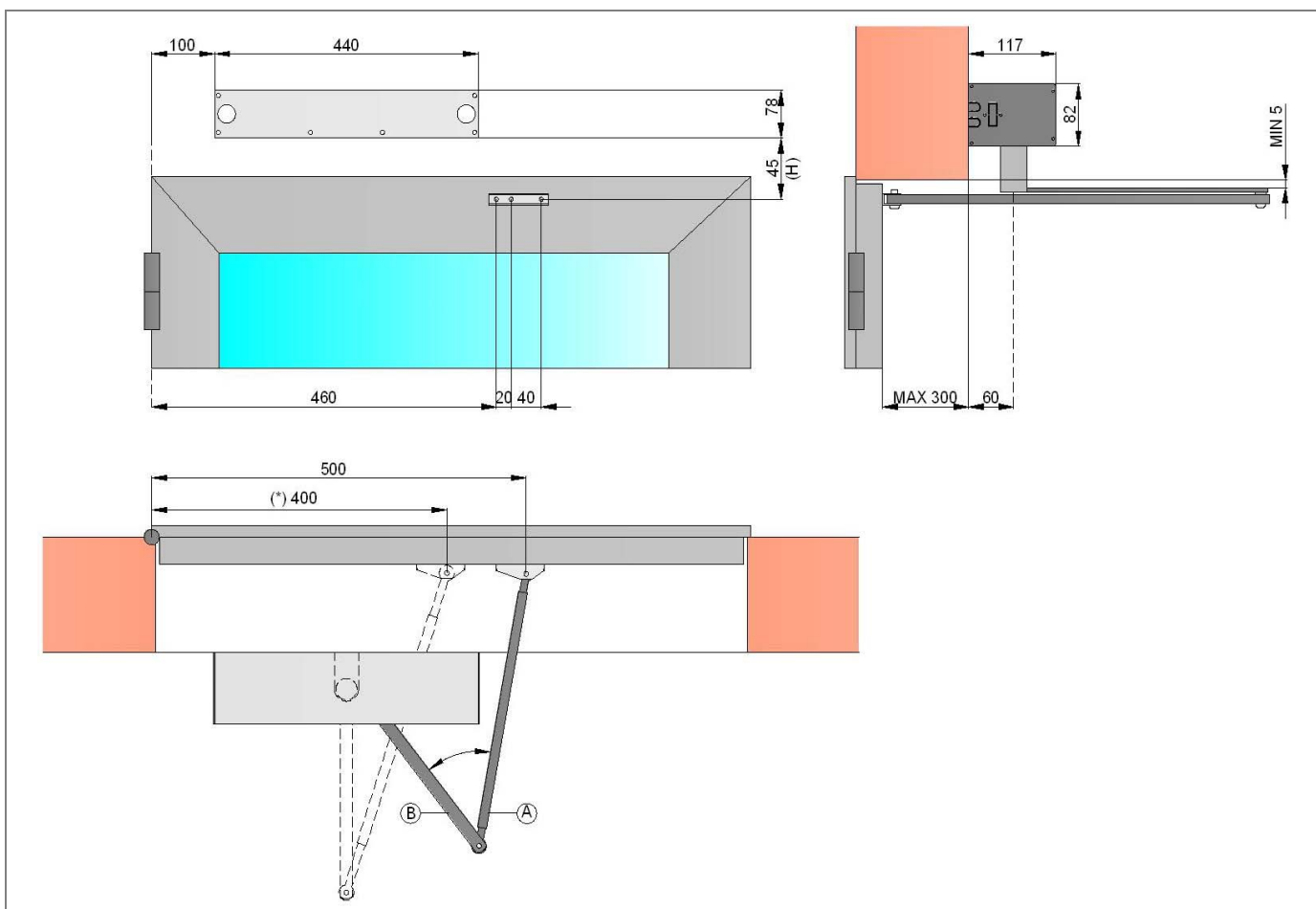

Note: if necessary, you can change the measure H, between the automation and the door, by replacing the spacer, using the codes listed in the table.

(H)	OVER automation
28	Articulated arm+ spacer H17
45	Articulated arm
62	Articulated arm + spacer H51

Fix the articulated arm to the automation, and fix the other end of the articulated arm to the door.

Move the door in the closed position, and adjust the length of the half-arm [A] so that the angle between the two half-arms [A] and [B] is the greater possible.

(*) To increase the opening force it is possible to reduce the angle and reduce the measurement of fixing of the articulated arm, as shown in figure.

Move the door manually, and verify the correct opening and closing smoothly.

Install the opening mechanical stop (not supplied by us).

Note: the mechanical stop on the floor must be fixed in a visible position and must not create tripping hazard.

CLOSING OF THE AUTOMATION COVER

Insert the cover profile to the base profile and attach it to the heads. To prevent the cover from being opened without the use of a tool, you can remove the pins inserted into the cover, and secure the cover to the heads at the holes, using the screws 2,9 x9,5 not supplied by us.

4.3 INSTALLATION OF OVER EVO AUTOMATION WITH SLIDING ARM

Use the sliding arm to pull with doors which open inside (view from the automation).

If the door has the hinge on the right, disassemble the gear motor group from the automation and move the spring group from the left side to the right side of the automation, as shown in the figure.

Factory setting

Hinge on the right

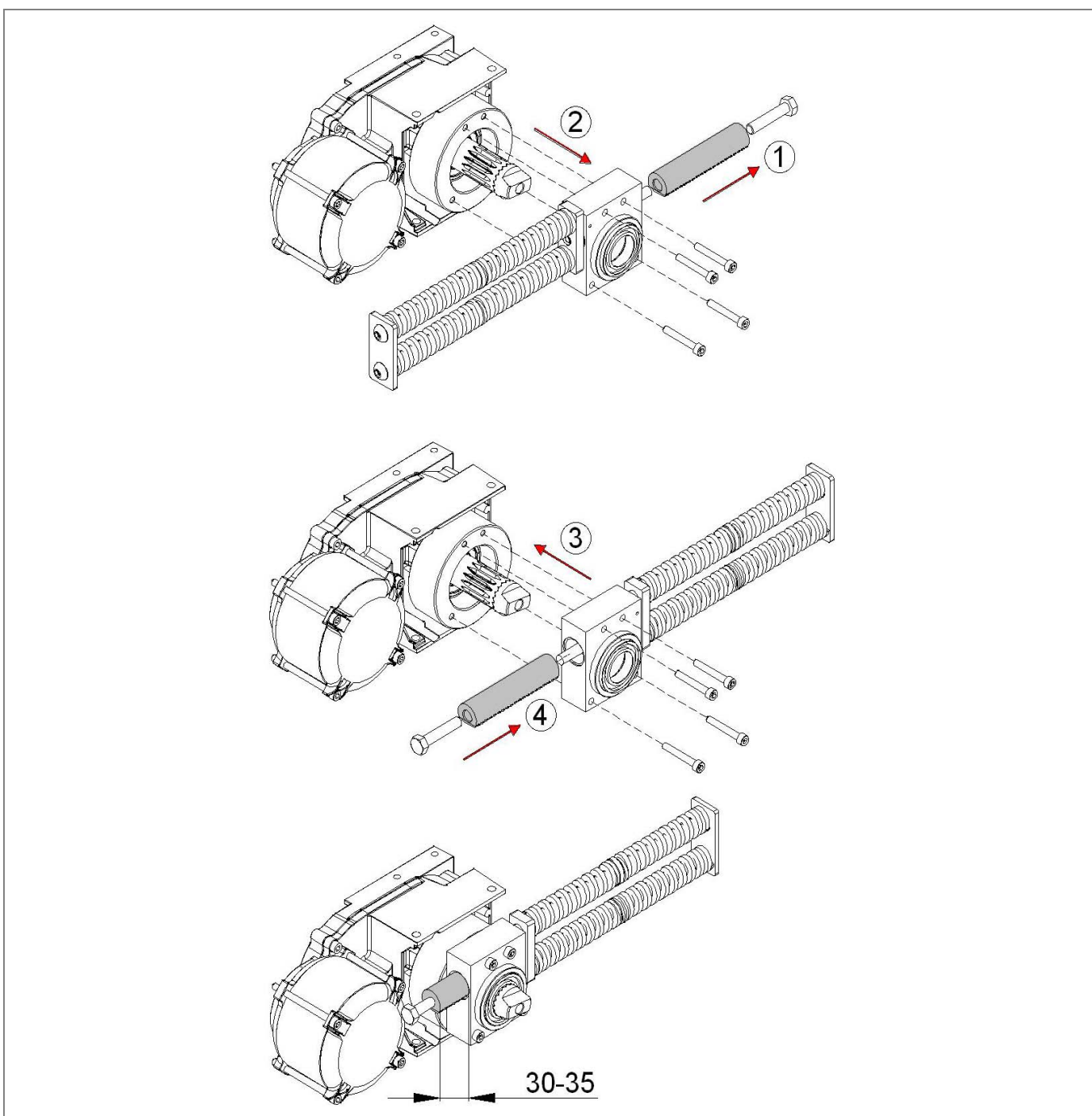
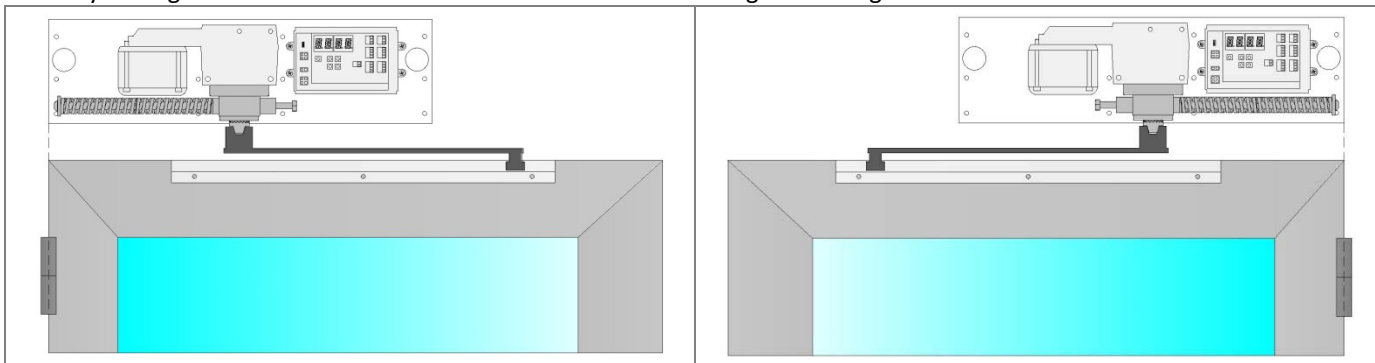

Remove the cover and fix the automation in a stable and leveled way to the wall using the measurements shown in the figure; refer to the axis of the door hinges.

Fix the sliding arm on the door as shown in the figure. Insert the sliding arm in the guide and fix to the automation (use the screw M8 x 50)

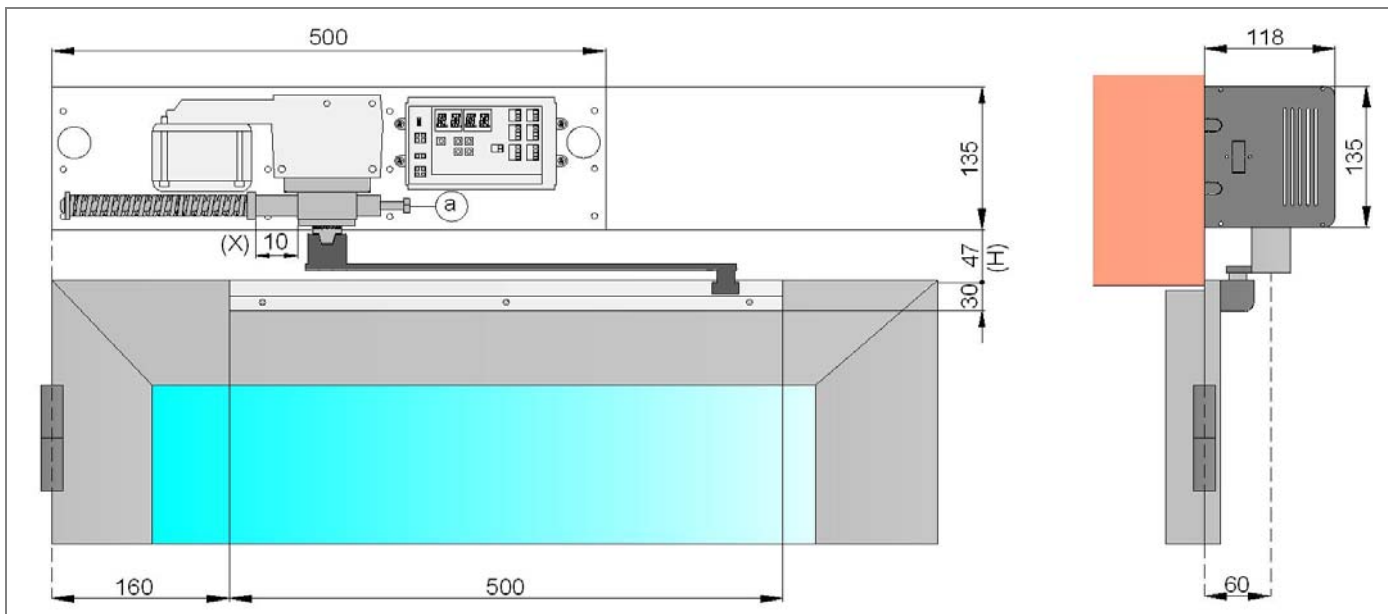

Note: if necessary, you can change the measure H, between the automation and the door, by replacing the spacer, using the codes listed in the table.

(H)	OVER EVO automation
30	Sliding arm + spacer H17
47	Sliding arm
64	Sliding arm + spacer H51

PRE-CHARGING OF THE CLOSING SPRINGS

Tighten the screw [a] and compress the springs of about X = 10 mm, as shown in the figure.

Move the door manually, and verify the correct opening and closing force.

Adjust the opening mechanical stop inside the sliding arm.

CLOSING OF THE AUTOMATION COVER

Attach the cover profile to the base profile. To prevent the cover from being opened without the use of a tool, you can secure the cover to the heads at the holes, using the screws 2,9 x9,5 not supplied by us.

4.4 INSTALLATION OF OVER EVO AUTOMATION WITH ARTICULATED ARM

Use the articulated arm to push with doors which open outside (view from the automation).

If the door has the hinge on the left, disassemble the gear motor group from the automation and move the spring group from the left side to the right side of the automation, as described in chapter 4.5.

Hinge on the left

Factory setting

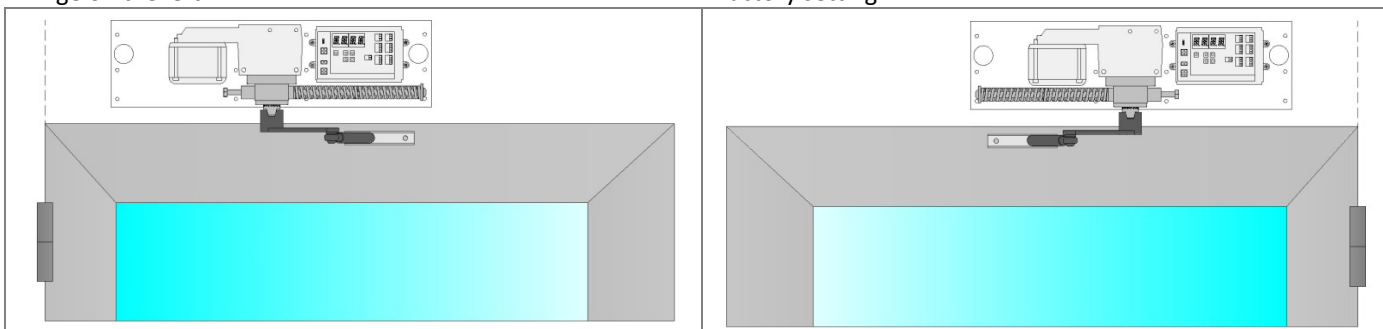

Remove the cover and fix the automation in a stable and leveled way to the wall using the measurements shown in the figure; refer to the axis of the door hinges.

Fix the bracket of the articulated arm on the door, using the measurements shown in the figure.

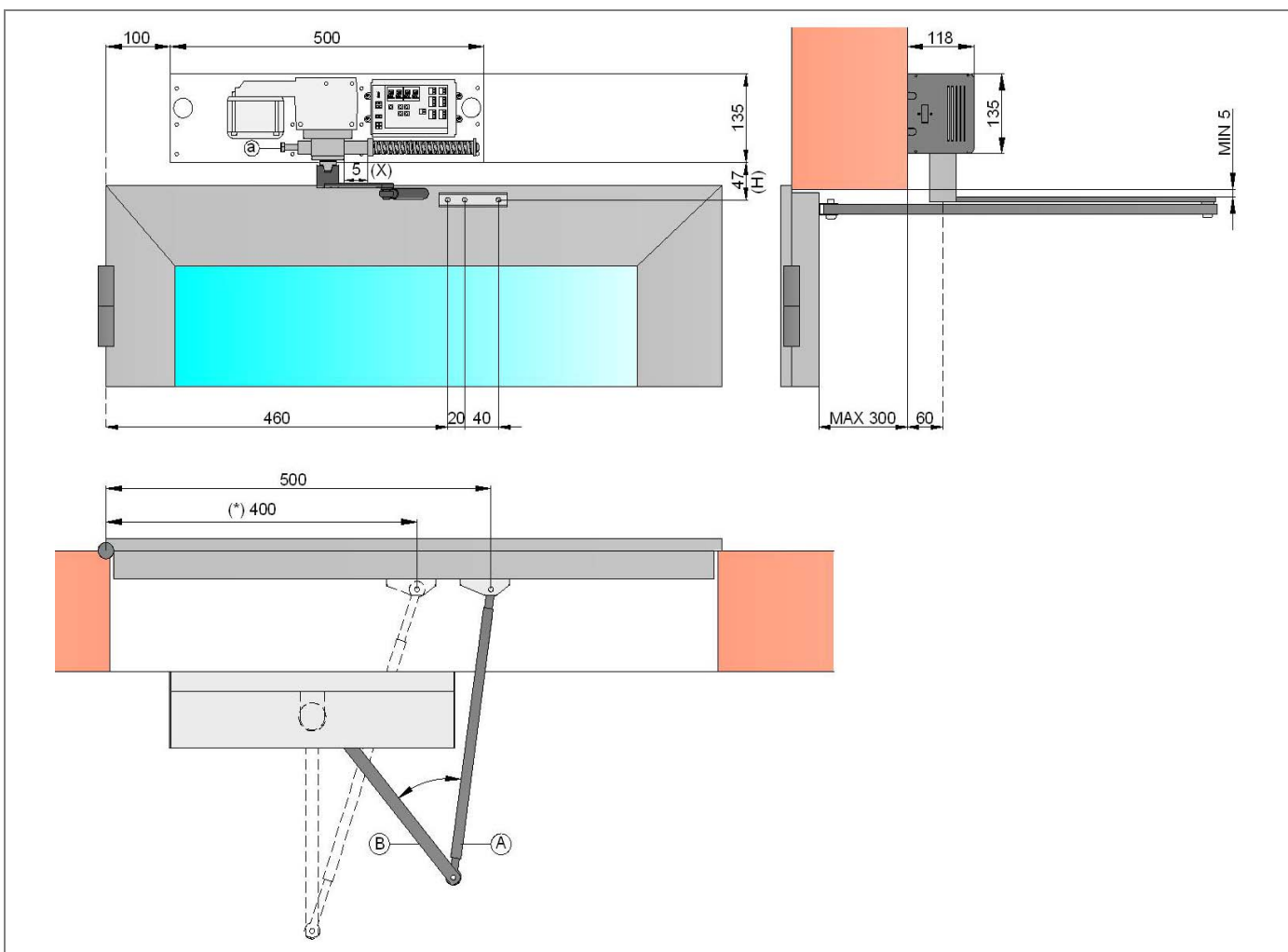

Note: if necessary, you can change the measure H, between the automation and the door, by replacing the spacer, using the codes listed in the table.

(H)	OVER EVO automation
30	Articulated arm + spacer H17
47	Articulated arm
64	Articulated arm + spacer H51

Fix the articulated arm to the automation (use the screw M8 x 50), and fix the other end of the articulated arm to the door.
Move the door in the closed position, and adjust the length of the half-arm [A] so that the angle between the two half-arms [A] and [B] is the greater possible.

(*) To increase the opening force it is possible to reduce the angle and reduce the measurement of fixing of the articulated arm, as shown in figure.

PRE-CHARGING OF THE CLOSING SPRINGS

Tighten the screw [a] and compress the springs of about $X = 5$ mm, as shown in the figure.

Move the door manually, and verify the correct opening and closing force.

Install the opening mechanical stop (not supplied by us).

Note: the mechanical stop on the floor must be fixed in a visible position and must not create tripping hazard.

CLOSING OF THE AUTOMATION COVER

Attach the cover profile to the base profile. To prevent the cover from being opened without the use of a tool, you can secure the cover to the heads at the holes, using the screws 2,9 x9,5 not supplied by us.

4.5 INSTALLATION OF OVER HEAVY AUTOMATION WITH SLIDING ARM

Use the sliding arm to pull with doors which open inside (view from the automation).

Remove the cover and fix the automation in a stable and leveled way to the wall using the measurements shown in the figure; refer to the axis of the door hinges.

Fix the sliding arm on the door as shown in the figure. Insert the sliding arm in the guide and fix to the automation.

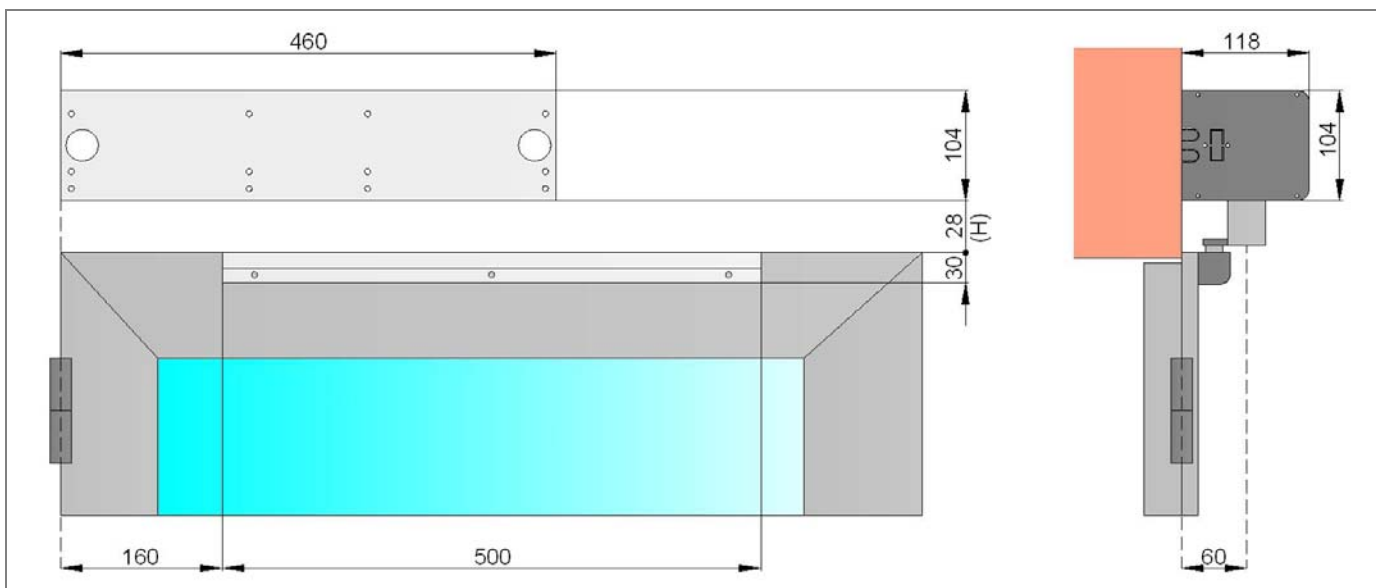

Note: if necessary, you can change the measure H, between the automation and the door, by replacing the spacer, using the codes listed in the table.

(H)	OVER HEAVY automation
28	Sliding arm
45	Sliding arm + spacer H51
62	Sliding arm + spacer H68

Move the door manually, and verify the correct opening and closing smoothly.

Adjust the opening mechanical stop inside the sliding arm.

CLOSING OF THE AUTOMATION COVER

Attach the cover profile to the base profile. To prevent the cover from being opened without the use of a tool, you can secure the cover to the heads at the holes, using the screws 2,9 x9,5 not supplied by us.

4.6 INSTALLATION OF OVER HEAVY AUTOMATION WITH ARTICULATED ARM

Use the articulated arm to push with doors which open outside (view from the automation).

Remove the cover and fix the automation in a stable and leveled way to the wall using the measurements shown in the figure; refer to the axis of the door hinges.

Fix the bracket of the articulated arm on the door, using the measurements shown in the figure.

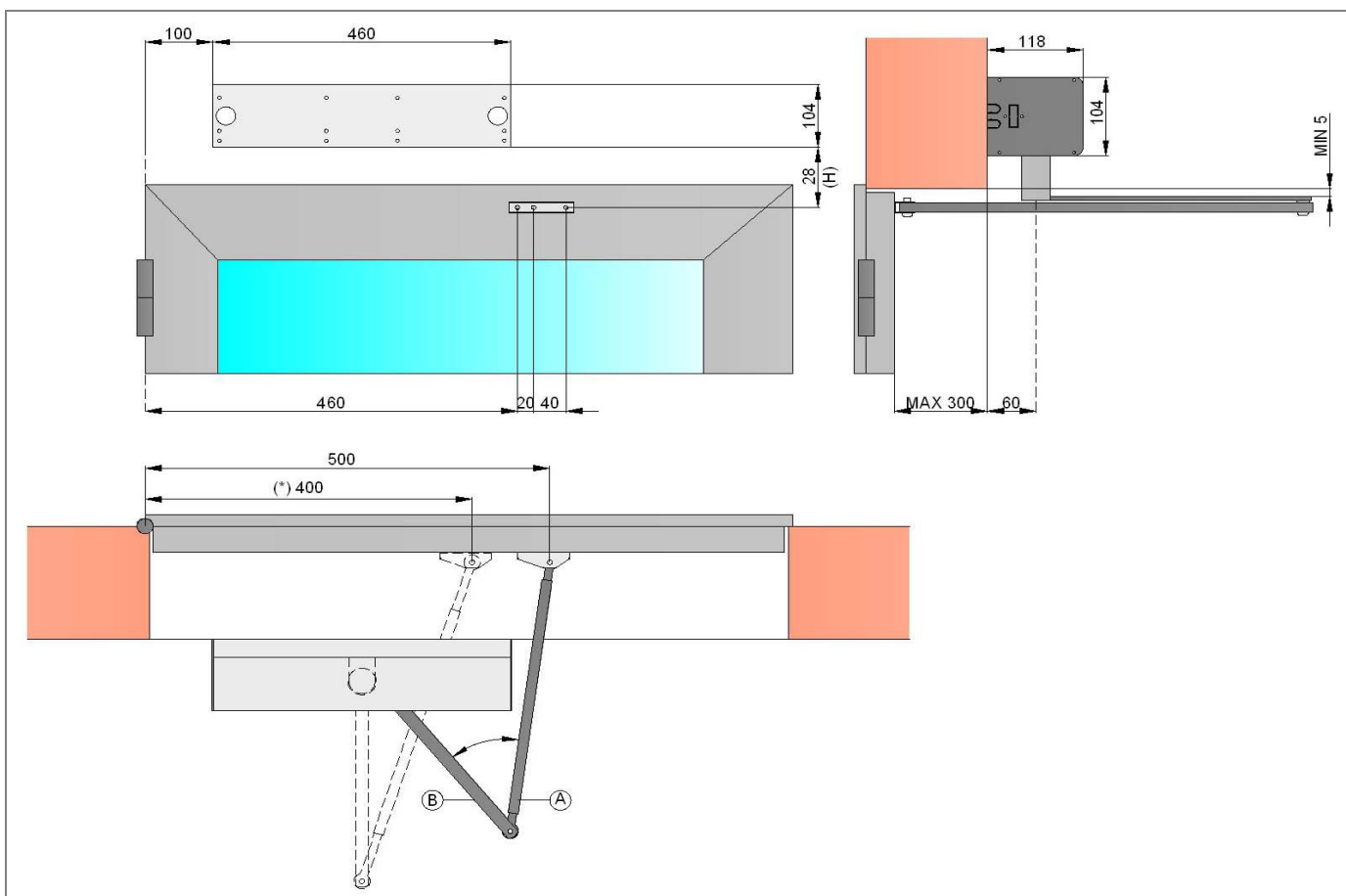

Note: if necessary, you can change the measure H, between the automation and the door, by replacing the spacer, using the codes listed in the table.

(H)	OVER HEAVY automation
28	Articulated arm
45	Articulated arm + spacer H51
62	Articulated arm + spacer H68

Fix the articulated arm to the automation, and fix the other end of the articulated arm to the door.

Move the door in the closed position, and adjust the length of the half-arm [A] so that the angle between the two half-arms [A] and [B] is the greater possible.

(*) To increase the opening force it is possible to reduce the angle and reduce the measurement of fixing of the articulated arm, as shown in figure.

Move the door manually, and verify the correct opening and closing smoothly.

Install the opening mechanical stop (not supplied by us).

Note: the mechanical stop on the floor must be fixed in a visible position and must not create tripping hazard.

CLOSING OF THE AUTOMATION COVER

Attach the cover profile to the base profile. To prevent the cover from being opened without the use of a tool, you can secure the cover to the heads at the holes, using the screws 2,9 x9,5 not supplied by us.

5. INSTALLATION OF BATTERY POWER DEVICE

5.1 Fix inside automation, on left side, the battery power device (OVER for OVER automation, or OVER HEAVY for OVER EVO and OVER HEAVY automation).

5.2 Connect the battery power device to the BAT connector of the electronic control, using the supplied cable.

5.3 Ensure that the battery is connected to the electronic board.

8.4 Connect the automation to the power supply and wait at least 30 minutes to let the battery recharge. Make sure that removing the power supply, the door is working with battery power device, in mode choice using the BTMD menu.

Note: to allow recharging, the battery power device must always be connected to the electronic control. In case of long periods of inactivity of the automatic door, disconnect the battery from the electronic board.

5.5 If desired, you can connect a LED to signal the presence of the battery (not supplied) between the terminals [+] and [LD] as shown in the figure. In the presence of mains power, the LED makes a blink every 10 seconds, while in the absence of mains power, the LED remains lit.

5.6 In the absence of mains power, battery operation is disabled when the charge level of the battery is too low.

If desired, you can connect a N.O. contact to reactivate the battery operation (example a key switch, not supplied) between the terminals [+] and [KY] as shown in Figure.

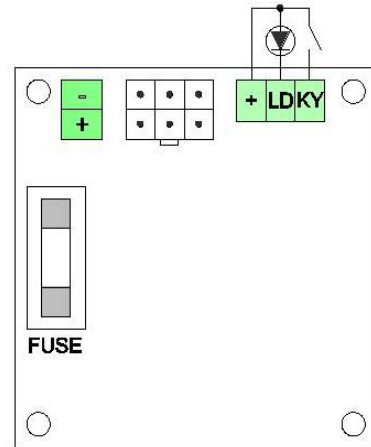
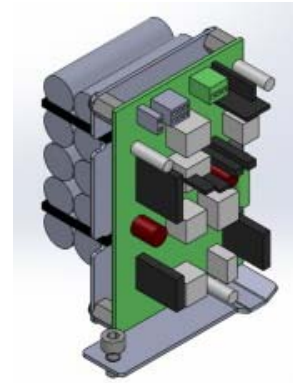

7. ELECTRICAL CONNECTIONS

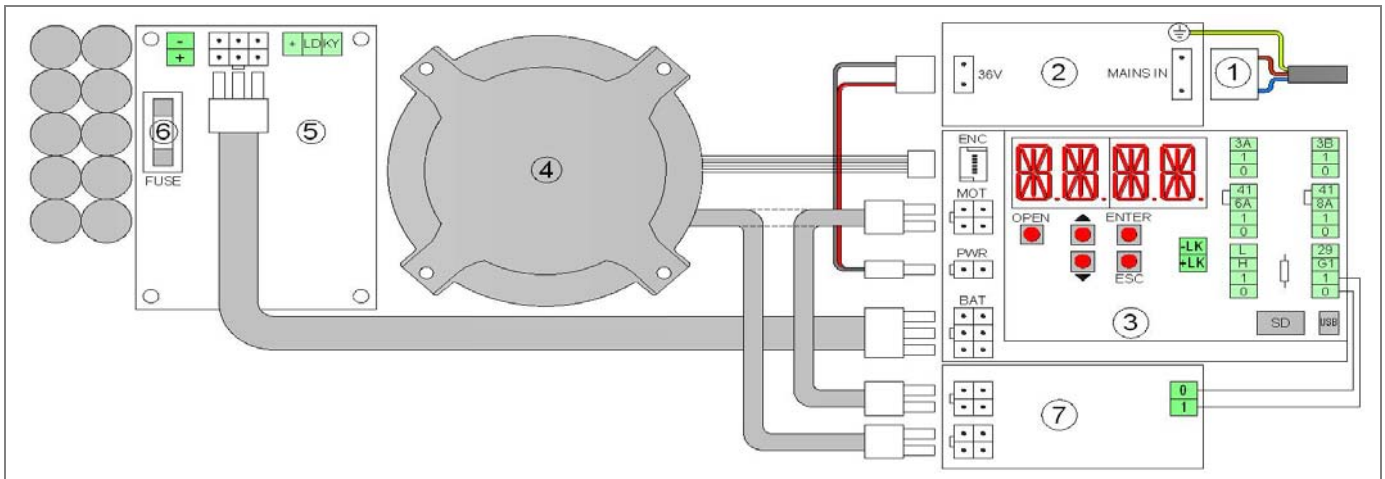

Rif.	Terminals	Description
1	MAINS IN	Cable for connection to the power supply.
2	PWR	Switching power supply 36V 65W (for OVER automation) Switching power supply 36V 75W (for OVER EVO and OVER HEAVY automation)
3		Electronic control
4	MOT	Brushless motor (for OVER automation) Brushless motor (for OVER EVO and OVER HEAVY automation)
	ENC	Angular sensor
5	BAT	Battery power device (for OVER automation) Battery power device (for OVER EVO and OVER HEAVY automation)
6	FUSE	Battery fuse 5x20 - F10A
7	MOT	Braking card (for OVER EVO automation)

7.1 GENERAL SAFETY ELECTRICAL PRECAUTIONS

Installation, electrical connections and adjustments must be completed in conformity with Good Working Methods and with regulations in force.

Before making power connections, check that the rating corresponds to that of the mains supply. A multipolar disconnection switch with a contact opening gap of at least 3 mm must be included in the mains supply. This switch must be protected from unauthorized activations.

Check that upstream of the electrical installation an adequate residual current circuit breaker and an overcurrent cut out are fitted.

When requested, connect the automation to an effective earthing system carried out as indicated by current safety regulations.

During installation, maintenance and repair operations, cut off the power supply before opening the cover to access the electrical parts.

To handle electronic parts, wear earthed antistatic conductive bracelets. APRIMATIC declines all responsibility in the event of components which are not compatible with the safe and correct operation of the product.

For repairs or replacements of products only original spare parts must be used.

7.2 POWER SUPPLY ELECTRICAL CONNECTION

Use the supplied cable for connection to electricity.

If the path of the power cord is outer portion automation, drill the cap on the suitable area, and route the power cable through a channel (not supplied by us) to the junction box.

Make sure there are no sharp edges that might damage the power cable.

The connection to the mains supply in the outer portion automation, should be an independent channel, separated from the connections to control and safety devices.

7.3 ELECTRONIC CONTROL TERMINALS

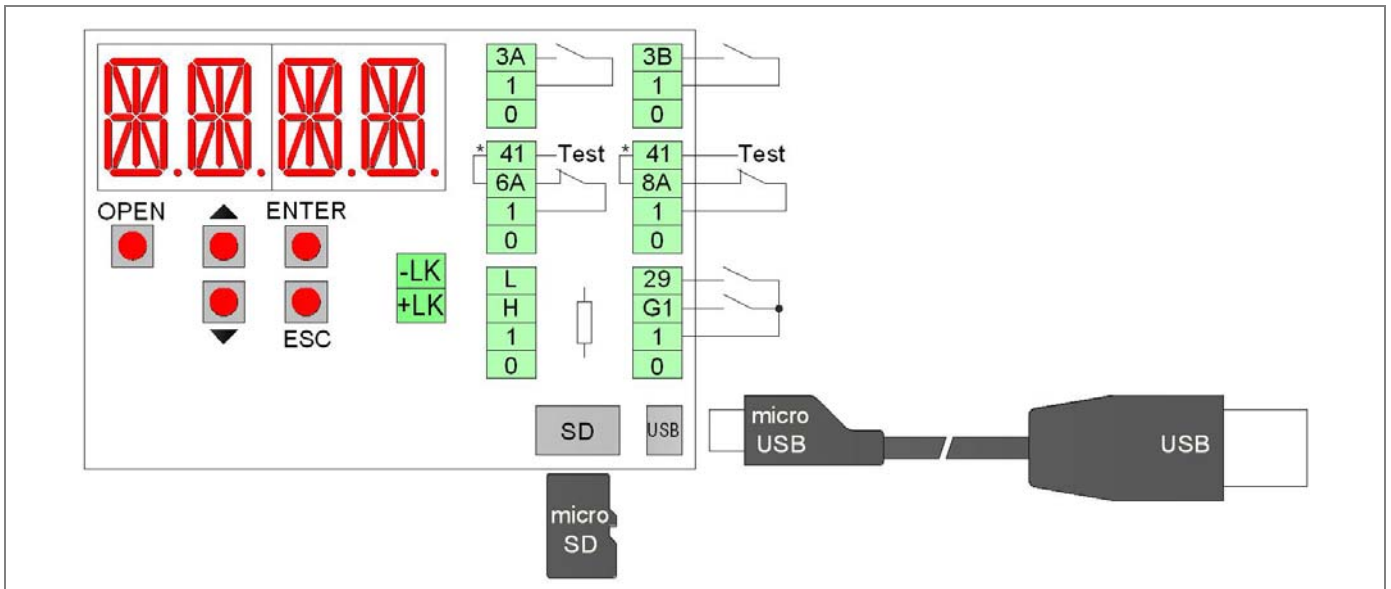

Note: The terminals with the same number are equivalent.

The electronic control comes with the jumpers on the terminals with an asterisk [*]. When connecting safety devices remove the jumpers of the corresponding terminals.

Terminals	Description
0 – 1	Output 12 Vdc for external powering accessories. The maximum absorption of 1 A corresponds to the sum of all the terminals 1 (+12V).
1 – 3A	Contact N.O. opening A side (interior side).
1 – 3B	Contact N.O. opening B side (outer side).
1 – 8A	Closing safety contact N.C. The opening of the contact causes the reversal of the movement. Note: connect safety devices with test (see terminal 41), and remove the jumper 41 - 8A.
1 – 6A	Opening safety contact N.C. The opening of the contact stops the movement during the opening phase; the door closes after 3s. If the automation is closed, the opening of the contact prevents the opening. Note: connect safety devices with test (see terminal 41), and remove the jumper 41 - 6A.
41	Output test (+12 V). Connect the safety devices with test (in accordance with EN 16005), as indicated in the following chapters. Note: in case of devices without test, connect the N.C. contact to terminals 41 - 8A or 41 - 6A.
1 – G1	Input terminal provided for general use.
0 – G1	Output terminal (12 Vdc, 20 mA max) provided for general use. Using the ADV > STG1 menu you can choose a specific function to the G1 terminal.
1 – 29	Reset contact N.O. Closure and release the contact starts the learning operation of the door.
0 – 1 – H – L	Bus connection to the FSD1 function selector.
+LK / -LK	Output 12V-24V (1A max) for electric lock.
SD	Standard admission for memory cards Micro SD. Allows saving the door settings and loading the firmware updates.
USB	Standard micro USB connection. Allows connection to a personal computer.

Buttons	Description
OPEN	Open the door.
↑	Scroll the menu and increase of selected values.
↓	Scroll the menu and reduction of selected values.
ENTER	Button to select the menu and save the selected data.
ESC	Exit the menu.

7.4 ELECTRICAL CONNECTION OF FUNCTION SELECTOR

Connect the 0-1-H-L terminals of the function selector, by cable (not supplied by us), to the 0-1-H-L terminals of the electronic control.

Note: for lengths over 10 m, use a cable with 2 twisted-pairs.

After connecting, the function selector is working. If you want to limit the use only by authorized personnel, proximity badges (13,56MHz ISO15693 and ISO14443 Mifare) must be activated by the function selector menu (max 50 badges).

The function selector allows the following settings.

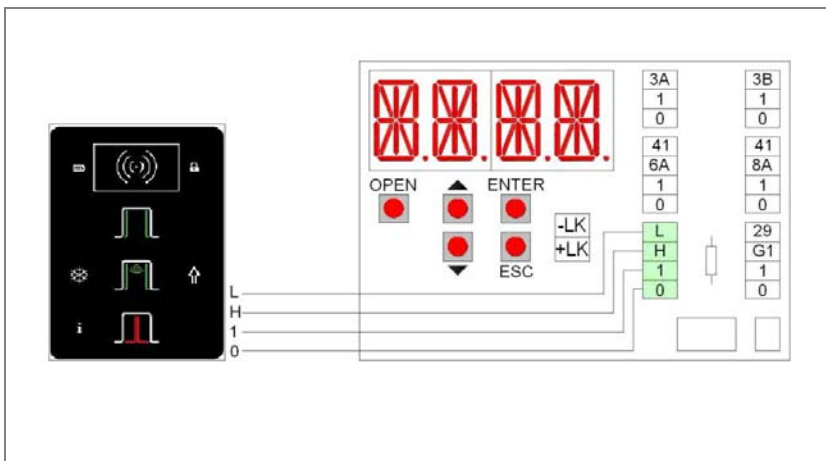

Symbol	Description
	Open Door. When selected, the symbol lights up, the door is permanently open. Note: the doors can still be handled manually.
	Automatic bi-directional operation. When selected, the symbol lights up and the doors full open automatic in bidirectional mode. Reset. Select the symbol for 5 seconds, the automation performs the self-test and the automatic learning.
	Automatic one-way operation. When selected, the symbol lights up and automatic operation of the door in one-way mode.
	Automatic partial operation. In the case of a door with 2 automations, when selected, the symbol lights and allows the automatic operation of only one leaf.
	Closed door. When selected, the symbol lights up and controls the permanent closure of the door. If the electric lock is present, the door is closed and locked. Note: using the menu SEL > DLAY you can adjust the delay time to close the door.
	Function selector is not active. The symbol lights up when the function selector is not active. To activate the temporary operation of the function selector is necessary to approach the badge, or select for 3 seconds the logo.
	Activation of the function selector. Select the prox logo for 3 seconds (the lock symbol light off), the function selector is activated for 10 seconds. Expired the time the function selector switches off (the lock symbol lights up).
	Authorized activation of function selector. Approach the badge (the lock symbol light off), the function selector is activated for 10 seconds. Expired the time the function selector switches off (the lock symbol lights up).
	Battery signal. Battery symbol off = the door is operating with the mains supply Battery symbol on = the door is operating with battery power Battery symbol flashing = the battery is low or disconnected
	Information signal. Information symbol on = it is necessary to perform the ordinary maintenance of the door. Information symbol flashing = shows the presence of alarms (as described in chapter 13.5): - 1 flash = failure of electronic control or locking device; - 2 flashes = mechanical failure; - 3 flashes = failure of sensor safety test; - 4 flashes = motor overtemperature.

7.5 ELECTRICAL CONNECTION OF OPENING SENSOR

Connect the sensor [PrimeMotionB], using the supplied cable to the terminals of the electronic control as follows:

- white wire = terminal 0
- brown wire = terminal 1
- yellow wire = terminal 1
- green wire = terminal 3A or 3B

For more information, check the installation manual of the sensor.

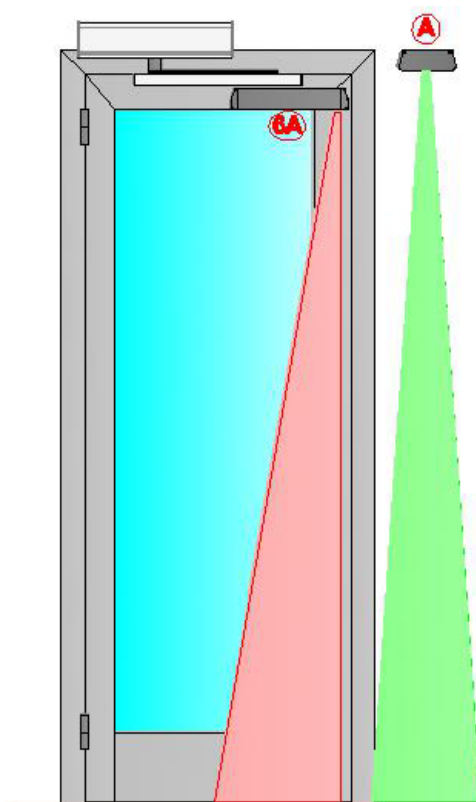

Example

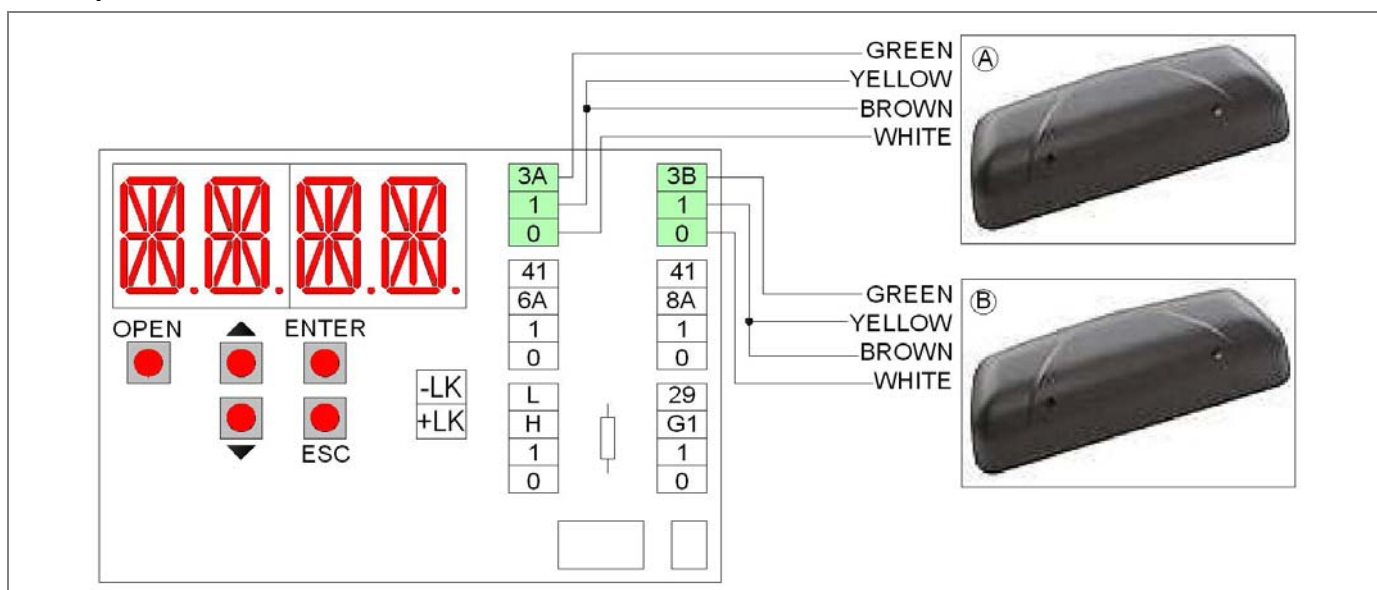

7.6 ELECTRICAL CONNECTION OF SAFETY SENSOR

The safety sensors should be installed directly on the door swing, and protect both the opening and the closing of the door swing.

If you install two sensors, they are connected to each other via the supplied cable, and only one of them is connected to the terminals of the electronic control as shown below.

For more information, check the installation manual of the sensor.

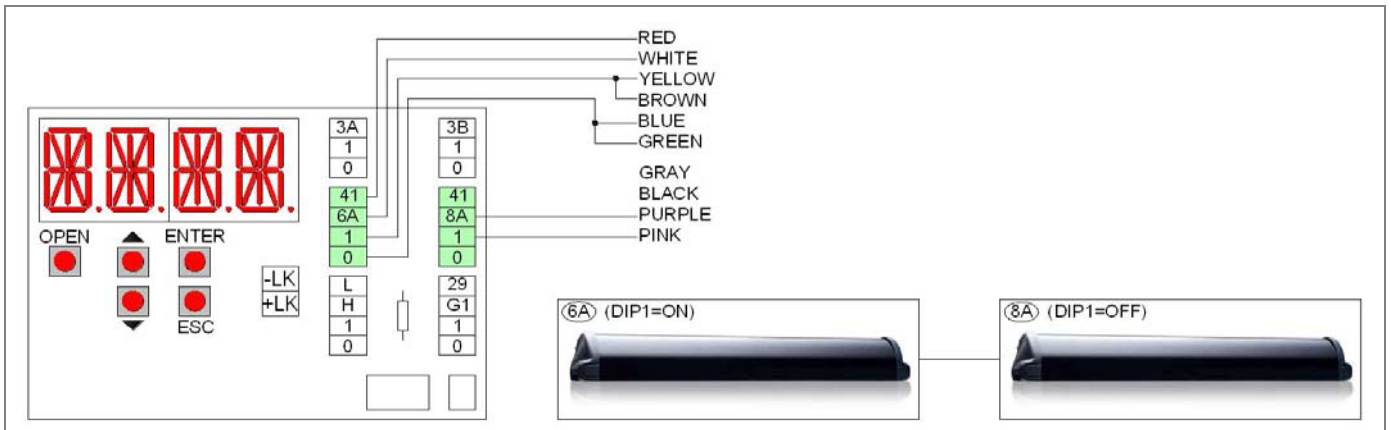
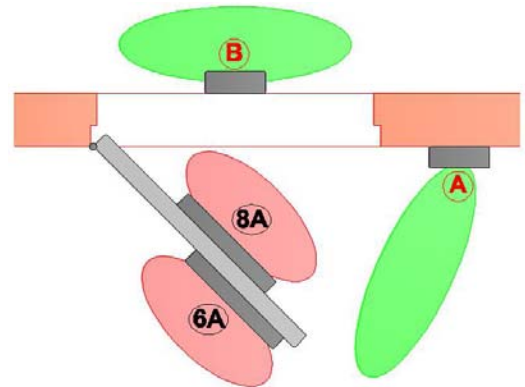

6A SENSOR (WITH DIP1=ON)

Connecting the safety opening sensor 6A (set DIP1=ON) of the swing door.

green wire = terminal 0

blue wire = terminal 0

brown wire = terminal 1

yellow wire = terminal 1

white wire = 6A terminal (remove the jumper 41-6A)

red wire = terminal 41

pink wire = do not connect

purple wire = do not connect

gray wire = do not connect

black wire = do not connect

8A SENSOR (WITH DIP1=OFF)

Connecting the safety closing sensor 8A (set DIP1=OFF) of the swing door.

green wire = terminal 0

blue wire = terminal 0

brown wire = terminal 1

pink wire = terminal 1

purple wire = 8A terminal (remove the jumper 41-8A)

red wire = terminal 41

yellow wire = do not connect

white wire = do not connect

gray wire = do not connect

black wire = do not connect

6A SENSOR (WITH DIP1=ON) + 8A SENSOR (WITH DIP1=OFF)

Connection of 2 safety sensors for opening 6A (set DIP1=ON) and closing 8A (set DIP1=OFF) of the swing door.

green wire = terminal 0

blue wire = terminal 0

brown wire = terminal 1

yellow wire = terminal 1

white wire = 6A terminal (remove the jumper 41-6A)

red wire = terminal 41

pink wire = terminal 1

purple wire = 8A terminal (remove the jumper 41-8A)

gray wire = do not connect

black wire = do not connect

7.9 ELECTRICAL CONNECTION OF SWFD FUNCTION SWITCH

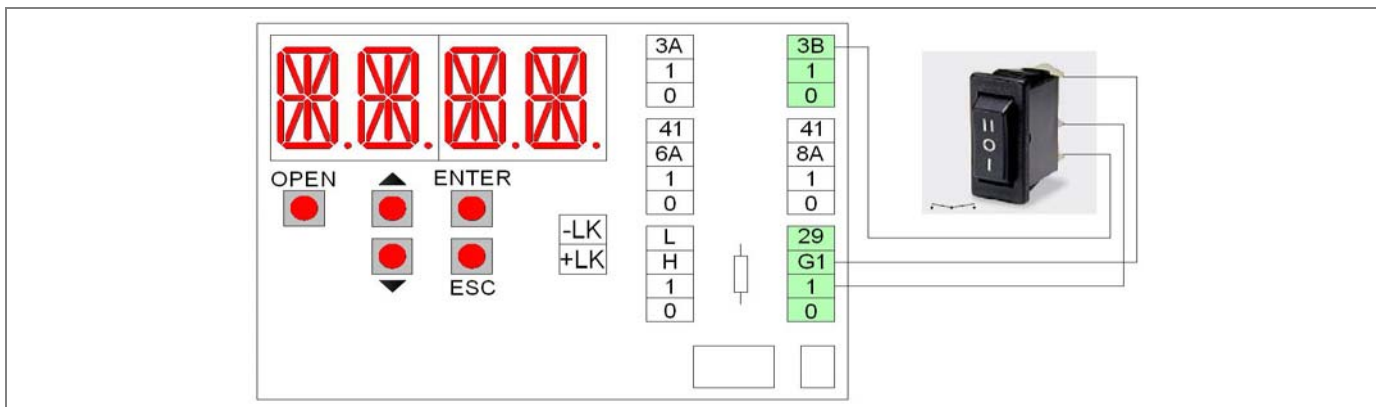

The SWFD function switch fixed directly on the automation.

Connect the function switch, using the supplied cable to the terminals of the electronic control as shown in figure (menu setting: ADV> STG1 > KC).

Symbol	Description
II	Open Door. When selected, the door is permanently open. Note: the door can still be handled manually.
O	Automatic bi-directional operation. When selected, the door open and close automatic in bidirectional mode.
I	Closed door. When selected, the door is permanently closed. If the electric lock is present, the door is closed and locked.

7.13 ELECTRICAL CONNECTION OF RADIO RECEIVER

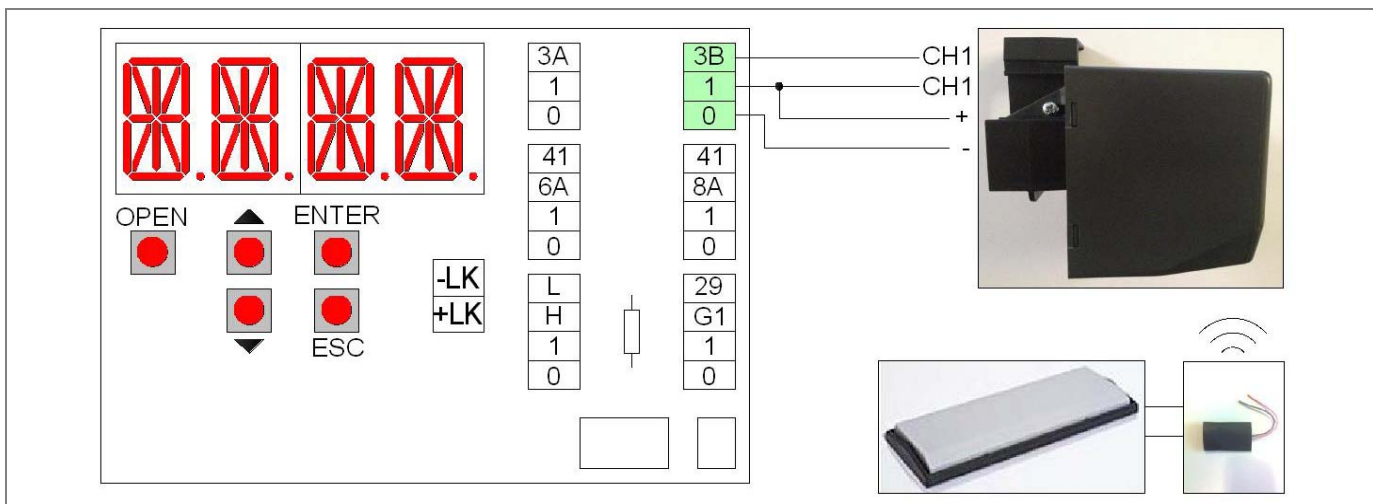

The radio receiver can be housed inside the automation, to the left of the gearmotor.

Connect the terminals of the radio receiver [MRC4E], by cable not supplied by us, to the terminals of the electronic control as follows:

terminal + = terminal 1

terminal - = terminal 0

terminal CH1 = terminal 1

terminal CH1 = terminal 3A, or terminal 3B

For more information, refer to the installation manual of the radio receiver.

8. ELECTRONIC CONTROL ADJUSTEMENT

The electronic control has 4 buttons and 4 alphanumeric displays to set all the necessary adjustments.

After turning on the electronic control, the display shows the word "MENU". The operation of the four keys are indicated in the table.

Keys	Description	
ENTER	Select button, each time you press the button you enter on the selected parameter. Save button, pressing for 1 seconds you "SAVE" the selected value. MENU = Main parameters menu MEM = Memory management menu ADV = Advanced parameters menu SEL = Function selector menu INFO = Information and diagnostics menu	
ESC	Exit button, exit from all the parameter or exit from the menu.	
↑	Scroll button, each press selects a menu item or increases the value of the selected item.	
↓	Scroll button, each press selects a menu item or reduces the value of the selected item.	

8.1 BASIC SETTINGS MENU

Using the buttons ↑ and ↓ choose MENU, press ENTER to select and adjust the following main parameters:

Display	Description	Factory settings
OPEN	Setting the opening direction. Choose between the following values: ← = door hinged on left → = door hinged on right	←
VOP	Opening speed setting. Choose between the minimum and maximum: minimum value = 15 deg/s maximum value = 70 deg/s	50
VCL	Closing speed setting. Choose between the minimum and maximum: minimum value = 100 mm/s maximum value = 700 mm/s	50
TAC	Open door time setting. Choose between the minimum and maximum: NO = the door is always open minimum value = 1 s maximum value = 30 s	1
PUSH	Force setting. Choose between the minimum and maximum: minimum value = 1 maximum value = 10	10
BTMD	Setting operation of battery power device, in absence of electricity. Choose between the following values: NO = battery not connected EMER = emergency open CONT = continuation of normal operation of the door, with last cycle of opening Note: the number of operations with battery, depends on the efficiency of the battery, the weight of the doors and the present friction.	NO
ARM	Setting the type of arm. Choose between the following values: PULL = sliding arm PUSH = articulated arm	PULL
DOOR	Setting the automation type. Choose between the following values: OVER = OVER automation (LIGHT) OVER EVO = OVER EVO automation (SPRING) OVER HEAVY = OVER HEAVY automation (HEAVY)	OVER
LEAF	Setting the weight of the door. Choose between the following values: MIN = light door MED = medium door MAX = heavy door	MED
RAMP	Set the acceleration time. Choose between the minimum and maximum values: minimum value = 100 ms (maximum acceleration) maximum value = 2000 ms (minimum acceleration)	400

8.2 MEMORY MANAGEMENT MENU

Using the buttons ↑ and ↓ select MEM, press ENTER to select and adjust the following memory management menu.

Display	Description	Factory settings
FSET	Restore all settings to factory defaults. Choose between the following values: NO = no restore. YES = restore to factory settings.	NO
FW	Programming procedure of electronic control. Download the electronic control Firmware, available at www.Aprimaticspa.it in Download area. Extract the "BFDS" folder from the ".zip" file and copy it to a micro SD memory (not in subfolder). Insert the micro SD memory in the electronic control. From this menu, choose the firmware version you want (from 0200 to - - - -). Press ENTER until it starts the programming procedure that lasts about 30 seconds (the display shows "WAIT ••••"), at the end the display shows "SAVE". After the procedure, remove the micro SD memory from the electronic control and store it for future use. Note: in the case of programming error or missing firmware (W100), proceed as follows: disconnect the power supply, insert the micro SD memory, give power supply, the programming procedure starts automatically.	- - - -
SIN	You can upload the menu settings used in another automation, already stored in the micro SD memory. Choose between the following values: NO = no upload YES = upload the menu settings from the micro SD memory	NO
SOUT	You can save the menu settings of automation in use, in the micro SD memory. Choose between the following values: NO = no save YES = save the menu settings of automation in the micro SD memory	NO

8.3 ADVANCED PARAMETERS MENU

Using the buttons ↑ and ↓ select ADV, press ENTER to select and adjust the following advanced parameters.

Display	Description	Factory settings
6AEX	Exclusion of the operation of the sensor opening safety. Choose between the minimum and maximum values: minimum value = 0% maximum value = 50%	0
8AEX	Exclusion of the operation of the sensor closing safety. Choose between the minimum and maximum values: minimum value = 0% maximum value = 50%	0
STG1	Operation of the G1 terminal. Choose between the following values: NO = no function KO = opening command 1 - G1 KC = closing command 1 - G1 VOPN = N.O. opening limit-switch 1 - G1 STEP = Step-by-step contact N.O. The closing of the 1-G1 contact performs in sequence the opening-closing of the door. SAM = Automatic setting command of function selector. The closing of the 1-G1 contact changes the function selector mode (see menu: SEL > SAM and SEL > SAM2). EMER = Emergency opening contact N.C. The opening of the 1-G1 contact opens the door. BELL = Output 0-G1 (12Vdc 20mA). The output is activated for 3 seconds when people enter the store (through the sequential activation of the contacts: 1-3B and 1-3A). SIGN = Output 0-G1 (12Vdc 20mA). The output is activated when the door is in the closed or opening position (see menu: ADV > SIGN).	KC
ELLK	Selecting the electric lock. Choose between the following values: NO = electric lock not connected LOCK = standard electric lock (security operation) SAFE = anti-panic electric lock (safety operation)	NO
TRLK	Operating time of the electric lock. Choose between the minimum and maximum values: minimum value = 0,5 s maximum value = 5,0 s	0.5
TALK	Time advance operating electric lock. Choose between the minimum and maximum values: minimum value = 0,5 s maximum value = 5,0 s	0.5
PIPP	Setting of the opening push. Choose between the following values: NO = no push YES = push enabled	NO
PUCL	Setting the push on the closed mechanical stop. Choose between the following values: NO = no push MIN = light push MED = medium push MAX = heavy push	MIN
PUGO	Push opening activation. Choose between the following values: NO = off YES = active	YES
LKPW	Power supply electric lock. Choose between the following values: 12 = 12V electric lock 24 = 24V electric lock	12
LKSH	Setting of closing push for hooking the electric lock. Choose between the following values: NO = no push MIN = light push MED = medium push MAX = heavy push	MED

Display	Description	Factory settings
HOLD	Setting the push of keeping the door open. Choose between the following values: NO = no push MIN = light push MED = medium push MAX = heavy push	MIN
T41	Enable test for safety devices (in accordance with EN 16005). Choose between the following values: NO = test disabled YES = test enable	YES
MOT	Setting the manual friction of the door, by means of the electrical connection of the motor windings. Choose between the following values: OC = manual door opening without friction (motor with open circuit windings) SC = manual door opening with friction (motor with short-circuit windings)	SC
SIGN	Door position indication through the 0-G2 output (see menu: ADV > STG2 > SIGN). Choose between the following values: CLOS = closed door OPEN = open door	CLOS
TAKO	Open door time setting, after the 1-KO command. Choose between the minimum and maximum: minimum value = 1 s maximum value = 30 s NO = the door is always open NO = see MENU > TAC	NO
SYNC	Door with 2 leaves, setting of master-slave synchronization. Choose between the following values: NO = no synchronization (door with 1 leaf) MAST = automation which opens first SLAV = automation which closes first	NO
SDLY	Door with 2 leaves, setting of delay of movement between Master-Slave. Choose between the following values: NO = leaves without overlap MIN = minimum delay MED = medium delay MAX = maximum delay	MED

8.4 FUNCTION SELECTOR MENU (FSD1)

Using the buttons ↑ and ↓ select SEL, press ENTER to select and adjust the following function selector menu.

























Display	Description	Factory settings
MODE	<p>Displaying of operating mode of function selector device. Choose between the following values:</p> <p>NO = no mode OPEN = open door AUTO = automatic bi-directional operation CLOS = closed door 1D = automatic one-way operation PA = automatic operation of a single leaf (if the door has 2 leaves) 1DPA = automatic one-way operation of a single leaf (if the door has 2 leaves)</p>	NO
SECL	<p>How to activate the function selector. Choose between the following values:</p> <p>NO = function selector always accessible LOGO = function selector accessible by selecting the logo for 3 seconds TAG = function selector accessible with badge</p>	NO
DLAY	<p>Setting delay time function closed door. Choose between the minimum and maximum values:</p> <p>minimum value = 1 s maximum value = 5 min</p>	1
TMEM	<p>Badge saving procedure for function selector. Choose between the following values.</p> <p>NO = no badge saving SMOD = Saving badge for activation of the function selector: - press the ENTER button for 1 second, the display shows REDY, - approach the badge to the function selector (in front of logo), the display shows the badge code, - wait for 20 seconds or press the ESC button. OPEN = Saving badge for activation of priority opening (Key Open): - press the ENTER button for 1 second, the display shows REDY, - approach the badge to the function selector (in front of logo), the display shows the badge code, - wait for 20 seconds or press the ESC button. Note: if the badge is not recognized the display shows the message UNKN, or if the badge is already stored will show the message NOK. You can store a total maximum of 50 badges.</p>	NO
TDEL	<p>Badge cancellation procedure. Choose between the following values.</p> <p>NO = no badge cancellation YES = badge cancellation - press the ENTER button for 1 second, the display shows REDY, - approach the badge to the function selector (in front of logo), the display shows the badge code, - wait for 20 seconds or press the ESC button. Note: if the badge is not recognized the display shows the message UNKN.</p>	NO
TMAS	<p>It is possible to create master badge that allows the saving and the cancellation of the badges, without the use of the menu. Choose from the following values.</p> <p>NO = no badge saving MMOD = creation of the master badge to saving badges for function selector activation. - press the ENTER button for 1 second, the display shows REDY, - approach the badge to the function selector (in front of logo), the display shows the badge code, - wait for 20 seconds or press the ESC button. MOPE = creation of the master badge to saving the badges of opening priority (Key Open). - press the ENTER button for 1 second, the display shows REDY, - approach the badge to the function selector (in front of logo), the display shows the badge code, - wait for 20 seconds or press the ESC button. Note: if the badge is not recognized the display shows the message UNKN, or if the badge is already stored will show the message NOK. The use of the master badge is the following: - approach the master badge to the function selector (in front of logo), the buzzer emits 2 beeps at the beginning of the storage procedure, - approach the badges, that you want to store, one at a time, to the function selector (in front of logo), the buzzer emits 1 beep of confirmation storage, - wait for 20 seconds, the buzzer emits 2 beeps at the end of the storage procedure. Note: if the badge is not stored, the buzzer emits no beeps.</p>	NO

Display	Description	Factory settings
TERA	How to erase all stored badge. Choose between the following values: NO = no erase YES = cancellation of all badges	NO
SAM1	First setting of function selector, when the 1-G1 contact becomes closed. Set the menu ADV > STG1 > SAM. Connect the contact of a clock to 1-G1 terminals, and choose between the following values: OPEN = open door AUTO = automatic bi-directional operation CLOS = closed door 1D = automatic one-way operation	CLOS
SAM2	Second setting of function selector, when the 1-G1 contact becomes open. Set the menu ADV > STG1 > SAM. Connect the contact of a clock to 1-G1 (1-G2) terminals, and choose between the following values: OPEN = open door AUTO = automatic bi-directional operation CLOS = closed door 1D = automatic one-way operation	CLOS
FW	Programming procedure of function selector. Download the function selector Firmware, available at www.Aprimaticspa.it it in Download area. Extract the "BFDS" folder from the ".zip" file and copy it to a micro SD memory (not in subfolder). Insert the micro SD memory in the electronic control. From this menu, choose the firmware version you want (from 0200 to - - - -). Press ENTER until it starts the programming procedure that lasts about 30 seconds (the display shows "WAIT ••••"), at the end the display shows "SAVE". After the procedure, remove the micro SD memory from the electronic control and store it for future use. Note: in the case of programming error or missing firmware (W103), proceed as follows: disconnect the power supply, insert the micro SD memory, give power supply, and repeat the programming procedure from this menu.	- - - -
VER	Displaying the firmware version of function selector (eg = 0200).	- - - -

8.5 INFORMATION AND DIAGNOSTICS MENU

Using the buttons ↑ and ↓ select INFO, press ENTER to select and adjust the following information and diagnostics menu.

Display	Description	Factory settings
SHOW	Displaying information of warning and faults. Choose between the following values: CONT = the display shows the active contacts of the terminal blocks and the alarms. WARN = the display shows the alarms only.	CONT
VER	Displaying the firmware version of electronic control (eg = 0200).	----
CYCL	Shows the number of cycles of the door (1 = 1.000 cycles, 9000 = 9.000.000 cycles).	0000
SERV	Enabling the signaling of routine maintenance of the door. NO = no signaling 1 = 1.000 cycles 9000 = 9.000.000 cycles	0000
LOG	You can save the following information in the micro SD memory (swing_log.txt): the last 20 warnings, the menu settings, and the electronic devices connected to automation. Choose between the following values: NO = no save YES = save the information in the micro SD memory	NO

DISPLAY	FSD1-FLASH	WARNING	CHECK
W001		1 Encoder error	Check encoder connection
W002		1 Motor short circuit	Check the connection of the motor
W003		1 Motor control error	Electronic control failure
W010		2 Direction reversed	Check the presence of obstacles
W011		2 Running too long	Check the connection between the motor and leaf
W012		2 Running too short	Check the presence of obstacles
W013		2 Overrun	Check the mechanical stops
W100	-	- Programming error (CB03)	Repeat the programming procedure in MEM > FW menu
W103	-	- Programming error (FSD1)	Repeat the programming procedure in SEL > FW menu
W127	-	- Automation reset	The automation performs a self-test
W128		on No power supply	Check the power supply
W129		1 No battery	Check the battery connection
W130		1 Low Battery	Replace or recharge the battery
W140		3 6A safety test failure	Check the safety sensor connection
W142		3 8A safety test failure	Check the safety sensor connection
W145		4 Motor overtemperature (first step)	The door reduces the speed
W146		4 Motor overtemperature (second step)	The door stops
W150		2 Obstacle in opening	Check the presence of obstacles
W151		2 Obstacle in closing	Check the presence of obstacles
W152		2 Door locked open	Check the presence of locks
W153		2 Door locked closed	Check the presence of locks
W156		2 Door moved manually	Wait about 5 seconds
W160		1 Synchronization error	Check the ADV > SYNC menu
W256		- Power on	-
W257		- Firmware update	-
W320		on Signaling of maintenance	Check the INFO > SERV menu
W330		1 Tuning between motor and electronics	Wait about 3-30 seconds

9. START-UP PROCEDURE OF THE AUTOMATIC SWING DOOR

9.1 Preliminary checks.

At the end of the installation, move the doors manually and make sure that operation is smooth and without friction. Check the solidity of the structure and the proper attachment of all the screws. Check the correctness of all electrical connections. Make sure you have installed the mechanical stop of the open door.

9.2 Before connecting any security devices, leave the jumper on terminals safety (41-6A, 41-8A).

9.3 Giving power supply and connect the battery, if present.

Note: every time you switch on the automation performs a self-test (from 3 to 30 seconds). The first opening and closing cycle is at low speed to allow the automatic learning.

9.4 To ensure that the electronic control has the factory settings, restore via the menu:

MEM> FSET> YES (confirm by pressing ENTER for 1 second).

Note: if the door is hinged on right, set as follow: MENU > OPEN > → (confirm by pressing ENTER for 1 second).

Note: if the door is with articulated arm, set as follow: MENU > ARM > PUSH (confirm by pressing ENTER for 1 second).

Note: if the door is OVER EVO (SPRING model), set as follow: MENU > DOOR > OVER EVO (confirm by pressing ENTER for 1 second).

Note: if the door is OVER HEAVY (HEAVY model), set as follow: MENU > DOOR > OVER HEAVY (confirm by pressing ENTER for 1 second).

9.5 Perform the menu settings as described in Chapter 8. Use OPEN button to perform the opening door, and verify the correct operation of the door.

Note: the automation automatically detects any obstacles during the closing movement (reversal movement) and opening (stopping movement).

9.6 If present, connect the electric lock of the door to the terminals (-LK \ +LK) of electronic control, and make the settings available in the ADV menu.

9.7 Connect one at a time, control and safety devices to protect the opening and closing cycle of the door, as described in Chapter 7.6, and verify proper operations.

Note: verify that the opening access is properly protected by safety sensors, in accordance with the requirements of the European standard EN16005 (annex C).

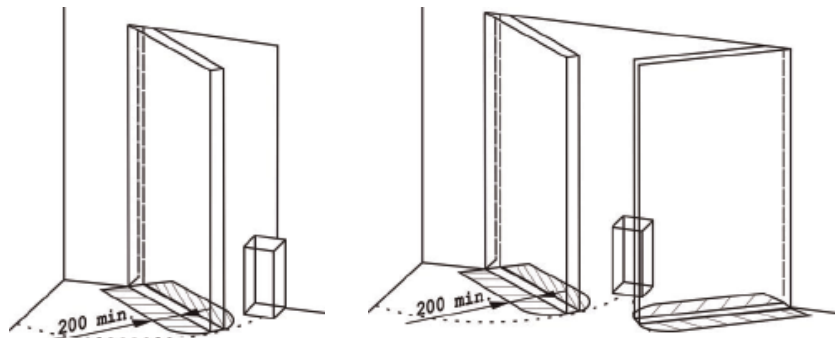

9.8 At the end of the automation starting, deliver to the owner the user instructions, including all warnings and information necessary to maintain the security and functionality of the automatic door.

9.9 APRIMATIC automations are feature of label containing the required information by European standards EN16005 and EN60335-2-103.

Note: the manufacturer of automatic swing door can add or change the label APRIMATIC with their product label.

APRIMATIC srl

Viale delle Industrie, 74 - 31030

E-mail: info@Aprimaticspa.it

www.Aprimaticspa.it

10. ADJUSTMENT OF THE KINETIC ENERGY OF THE DOOR

- To reduce the kinetic energy of the door make the following adjustments:
- adjust the force PUSH ≤ 5 ;
 - adjust the opening speed (VOP) so as to open the door (from 0° to 80°) at the times indicated in the table;
 - adjust the closing speed (VCL) so as to close the door (from 90° to 10°) at the times indicated in the table.

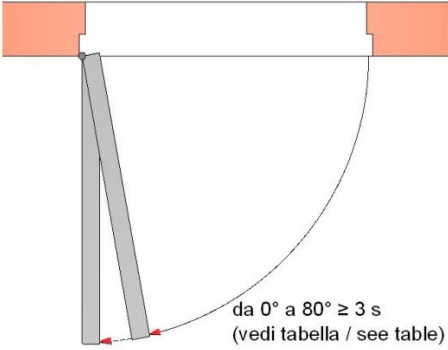
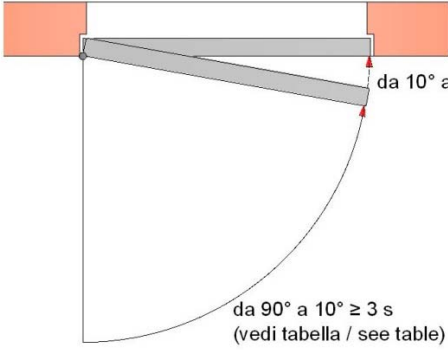
APERTURA / OPENING		CHIUSURA / CLOSING			
 <p>da 0° a 80° ≥ 3 s (vedi tabella / see table)</p>		 <p>da 10° a 0° $\geq 1,5$ s (vedi tabella / see table)</p>			
Door width	Door weight				
	50 kg	60 kg	70 kg	80 kg	90 kg
0,75 m	3,0 s	3,0 s	3,0 s	3,0 s	3,5 s
0,85 m	3,0 s	3,0 s	3,5 s	3,5 s	4,0 s
1,00 m	3,5 s	3,5 s	4,0 s	4,0 s	4,5 s
1,20 m	4,0 s	4,5 s	4,5 s	5,0 s	5,5 s

11. TROUBLESHOOTING

In addition to the following list of possible problems, there are warnings provided by the display, as described in chapter 8.5.

Problem	Possible causes	Remedy
The automation does not open or close.	No power supply (display off).	Check the power supply.
	Short circuited external accessories.	Disconnect all accessories from terminals 0-1 and reconnect them one at a time (check for voltage 12V).
	The door is locked by bolts and locks.	Check the freely move of the doors
The automation does not perform the functions set.	Function selector incorrectly set.	Check and correct the settings of the function selector.
	Control devices or safety always activated.	Disconnect devices from the terminal and verify the operation of the door.
The movement of the doors isn't linear, or reverse the movement for no reason.	The automation does not successfully perform the automatic learning.	Perform a reset using the command 1-29 , or power off and power on the automation.
The automation opens but does not close	Anomalies during the safety devices test.	Jumper contacts one at a time 41 -6A , 41 - 8A.
	The opening devices are activated.	Verify that the opening sensors are not subject to vibration , do not perform false detections or the presence of moving objects in the field of action.
	The automatic closing doesn't work.	Check the settings of the function selector .
Safety devices not activating.	Incorrect connections between the safety devices and electronic control.	Check that the safety contacts of the devices are properly connected to the terminal blocks and the relative jumpers have been removed.
The automation opens by itself.	The opening and safety devices are unstable or detect moving bodies	Verify that the opening sensors are not subject to vibration , do not perform false detections or the presence of moving bodies in the field of action.

12. AUTOMATIC SWING DOOR ROUTINE MAINTENANCE PLAN

To ensure proper operation and safe use of the automatic swing door, as required by European standard EN16005, the owner has to perform routine maintenance by qualified personnel.

Except for routine cleaning of the door, the responsibility of the owner, all maintenance and repair work must be carried out by qualified personnel.

The following table lists tasks related to routine maintenance, and the frequency of intervention related to an automatic swing door operation with standard conditions. In the case of more severe operating conditions, or in the case of sporadic use of the automatic swing door, the frequency of maintenance can be consistently adequate.

Task	Frequency
Remove the power supply, open the automation and perform the following checks and adjustments. - Check all screws fastening of components within the automation. - Check the state of wear of the hinges (if necessary replace them). - Verify correct mounting of the arm on the door. - In the case of OVER EVO automation, check the correct force of the closing spring. - If present, verify proper engagement of the electric lock.	Every 6 months or every 500.000 cycles.
Connect the power supply and perform the following checks and adjustments. - Check the correct operation of the control devices and safety. - Check the detection area of the security sensors complies with the requirements of the European standard EN16005. - If present, verify the correct operation of the electric lock. - If present, verify the correct operation of the battery power device (if necessary replace the battery).	Every 6 months or every 500.000 cycles. Note: the verification of the automation security functions and safety devices must be made at least 1 time per year.

All maintenance, replacement, repair, update, etc.. must be written into the proof book, as required by European standard EN16005, and delivered to the owner of the automatic swing door.

For repairs or replacements of products, original spare parts must be used.

12.1 DISPOSAL OF PRODUCTS



For correct disposal of electrical and electronic equipment, batteries and accumulators, the owner must deliver the product to special "collection centres" provided by municipalities.



APRIMATIC srl

E-mail: info@Aprimaticspa.it \ www.Aprimaticspa.it



